

# 1. Arm and bed

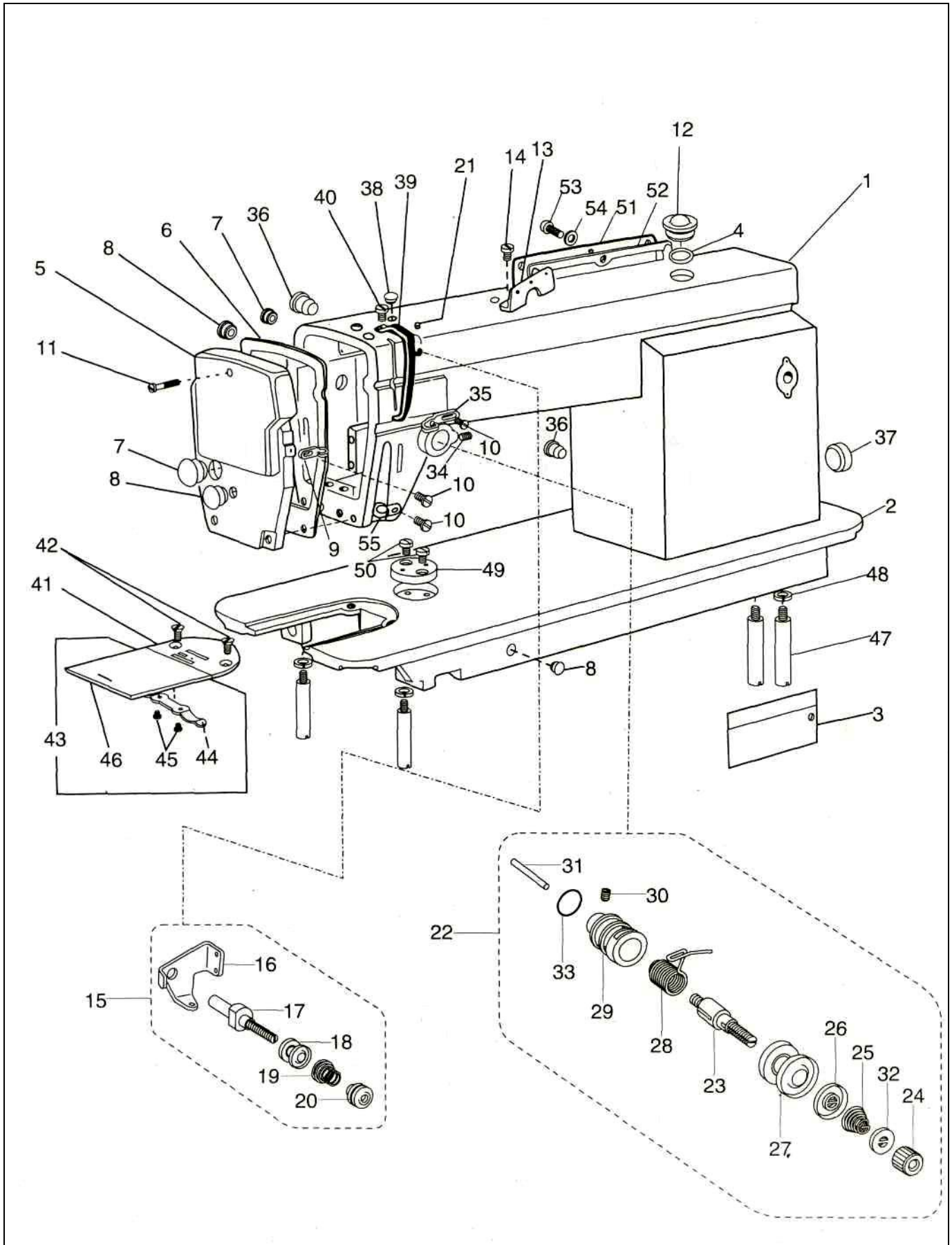

# 1. Arm and bed

No.	Part number	Name	Qt.	Remark
1	14WF4-002(15WF4-001)	Arm	1	Part number shown in parentheses is for GC202
2	14WF4-001(7WF4-001)	Bed	1	Part number shown in parentheses is for GC202
3	I4WF4-007(15WF4-002)	Trade mark plate	1	Part number shown in parentheses is for GC202
4	14WF4-006	O-type ring	1	White
5	14WF4-003A1	Face plate	1	
6	14WF4-004	Face plate gasket	1	
7	22T1-003C3	Rubber plug	2	Φ19
8	22T1-003C4	Rubber plug	3	Φ11.8
9	22T1-003C5	Thread finger	1	
10	22T1-003C6	Screw	3	
11	22T1-004	Screw	3	
12	14WF4-005	Oil screen	1	
13	36T2-004	Three eye finger	1	
14	36T2-005	Screw	1	
15	36T2-006D	Thread tension complete	1	
16	36T2-006D1	Thread pass-by plate	1	
17	36T2-006D2	Screw	2	
18	22T1-009E3	Tension disc	1	
19	36T2-006D3	Spring	1	
20	36T2-006D4	Nut	1	
21	22T1-011	Ste screw	1	
22	22T1-012F	Thread tension complete	1	
23	22T1-012F1	Screw	1	
24	22T1-012F2	Nut	1	
25	22T1-012(33T4-008C1)	Spring	1	Part number shown in parentheses is for GC202
26	22T1-012F4	Thread releasing plate	1	
27	22T1-012F5	Thread tension disc	2	
28	22T1-012F6	Thread take-up spring	1	
29	22T1-012F7	Thread tension adjusting bracket	1	
30	22T1-012F8	Screw	1	
31	22T1-012F9	Thread releasing pin	1	
32	22T1-012F10	Stopping plate	1	
33	22T1-012FM	O-type ring	1	
34	22T1-013	Set screw	1	
35	22T1-014	Thread finger	1	
36	22T1-015	Rubber plug	2	Φ8.8
37	22T1-016	Rubber plug	1	Φ27
38	22T1-017	Rubber plug	1	Φ5.7
39	34T4-007	Thread take-up lever guard	1	
40	22T2-004	Screw	1	
41	48T1-004(33T4-012-A)	Throat plate	1	Part number shown in parentheses is for GC202
42	22T1-020	Screw	2	
43	7WF4-006A	Sliding plate complete	1	
44	20T1-013F2	Spring	1	
45	20T1-013F3	Screw	2	
46	7WF4-006	Sliding plate	1	
47	7WF4-013	Bed leg	4	
48		Washer	4	Washer 6 GB93-87
49	7WF4-005	Holder	1	
50	1WF3-025	Screw	2	
51	22T1-005D1	Back side cover complete	1	
52	22T1-005D2	Seal gasket	1	
53	22T1-006	Screw	8	
54	22T 1-007	Washer	8	
55	7WF4-012	Thread finger	1	

## 2. Arm shaft. vertical shaft. needle bar and thread take-up

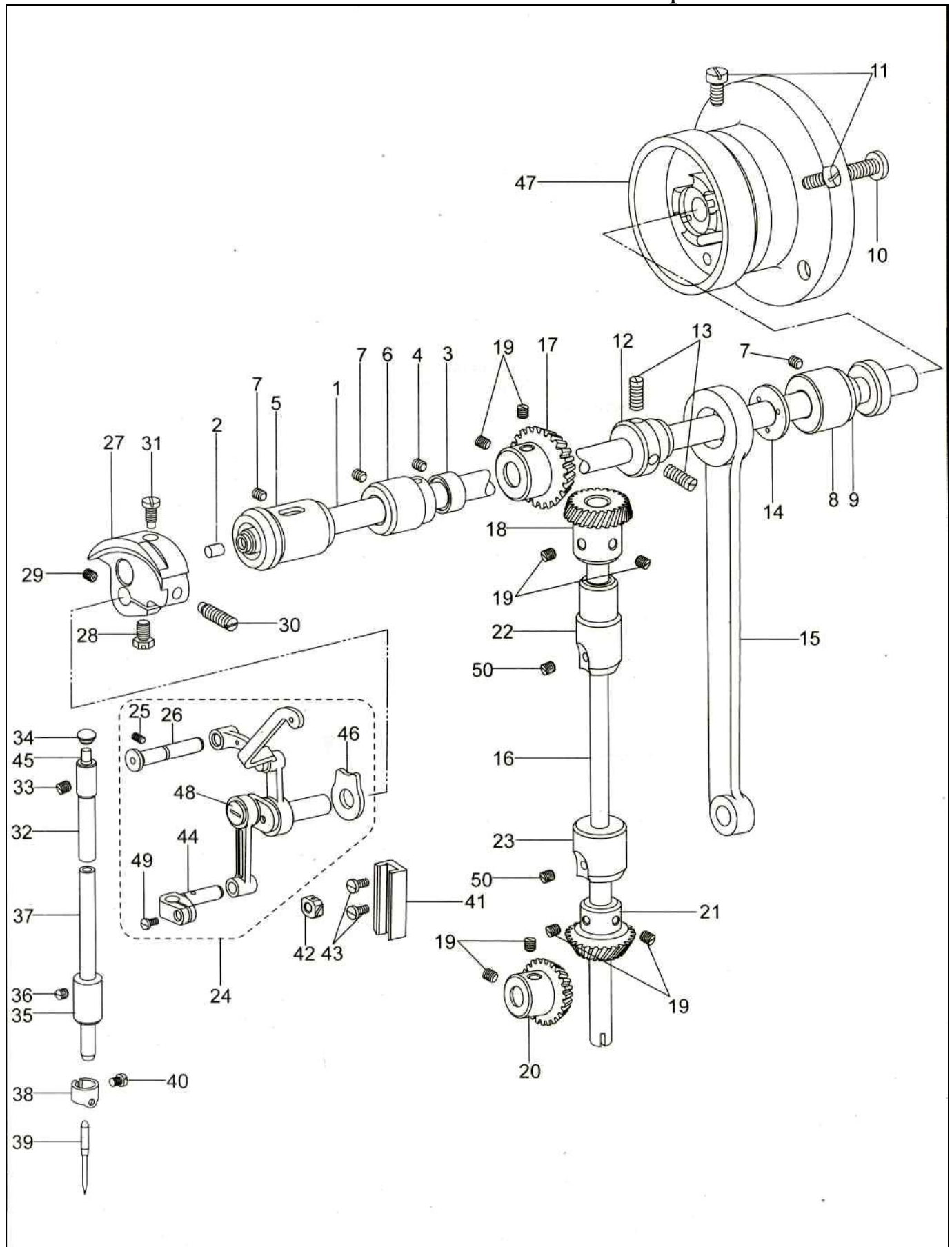

## 2. Arm shaft. vertical shaft. needle bar and thread take-up

No.	Part number	Name	Qt.	Remark
1	4WF1-001A	Arm shaft	1	
2	22T3-001A <sub>2</sub>	Rubber plug	2	
3	22T3-002B <sub>1</sub>	Collar	1	
4	22T3-002B <sub>2</sub>	Screw	2	
5	33T1-007D <sub>1</sub>	Front bushing	1	
6	4WF1-002	Middle bushing	1	
7	J0.0.40	Screw	3	
8	22T3-005	Rear bushing	1	
9	22T3-006F	Oil seal complete	1	
10	22T3-008	Screw	1	
11	22T3-007C <sub>2</sub>	Screw	2	
12	36T3-003D <sub>1</sub>	Feed dog lift cam	1	
13	36T3-003D <sub>2</sub>	Screw	3	
14	36T3-004	Separating piece for cam	1	
15	22T3-009D <sub>1</sub> C	Link	1	
16	22T3-010E <sub>1</sub> (15WF1-001)	Vertical shaft	1	Part number shown in parentheses is for GC202
17	22T3-010E <sub>2a1-2</sub>	Bevel gear	1	
18	22T3-010E <sub>2a2-2</sub>	Vertical shaft bevel gear (upper)	1	
19	22T2-005B <sub>3</sub>	Screw	8	
20	22T3-010E <sub>2b2-2</sub>	Rock shaft bevel gear	1	
21	22T3-010E <sub>2b2-2</sub>	Vertical shaft bevel gear (lower)	1	
22	4WF1-003A	Vertical shaft bushing (upper) complete	1	
23	33T1-023P	Vertical shaft bushing (lower) complete	1	
24	33T1-023A	Thread take-up lever complete	1	
25	J0.0.5	Screw	1	
26	33T1-002	Hinge pin	1	
27	33T1-006C <sub>1</sub>	Needle bar crank	1	
28	33T1-006C <sub>3</sub>	Screw	1	
29	22T2-005B <sub>3</sub>	Set screw	1	
30	33T1-006C <sub>2</sub>	Screw	1	
31	61-04-01/B2	Set screw	1	
32	22T2-008	Needle bar upper bushing	1	
33	J0.0.35	Screw-	1	
34	22T2-011	Rubber plug	1	
35	34T1-001	Needle bar lower bushing	1	
36	22T2-013	Screw	1	
37	33T1-017	Needle bar	1	
38	22T2-015	Thread finger	1	
39		Needle	1	DPX5 18 <sup>#</sup>
40	22T2-017	Screw	1	
41	33T1-012	Rail for sliding block	1	
42	33T1-013	Sliding block	1	
43	22T2-019	Screw	2	
44	22T2-001A <sub>8</sub>	Needle bar adapter	1	
45		Felt	1	
46	33T1-005	Washer	1	
47	7WF1-001	Balance wheel	1	
48	22T2-001A <sub>6</sub>	Screw	1	
49	22T2-001A <sub>9</sub>	Screw	1	
50	61-04-01 1B308	Screw	2	

### 3. Feed dog lift and thread looping

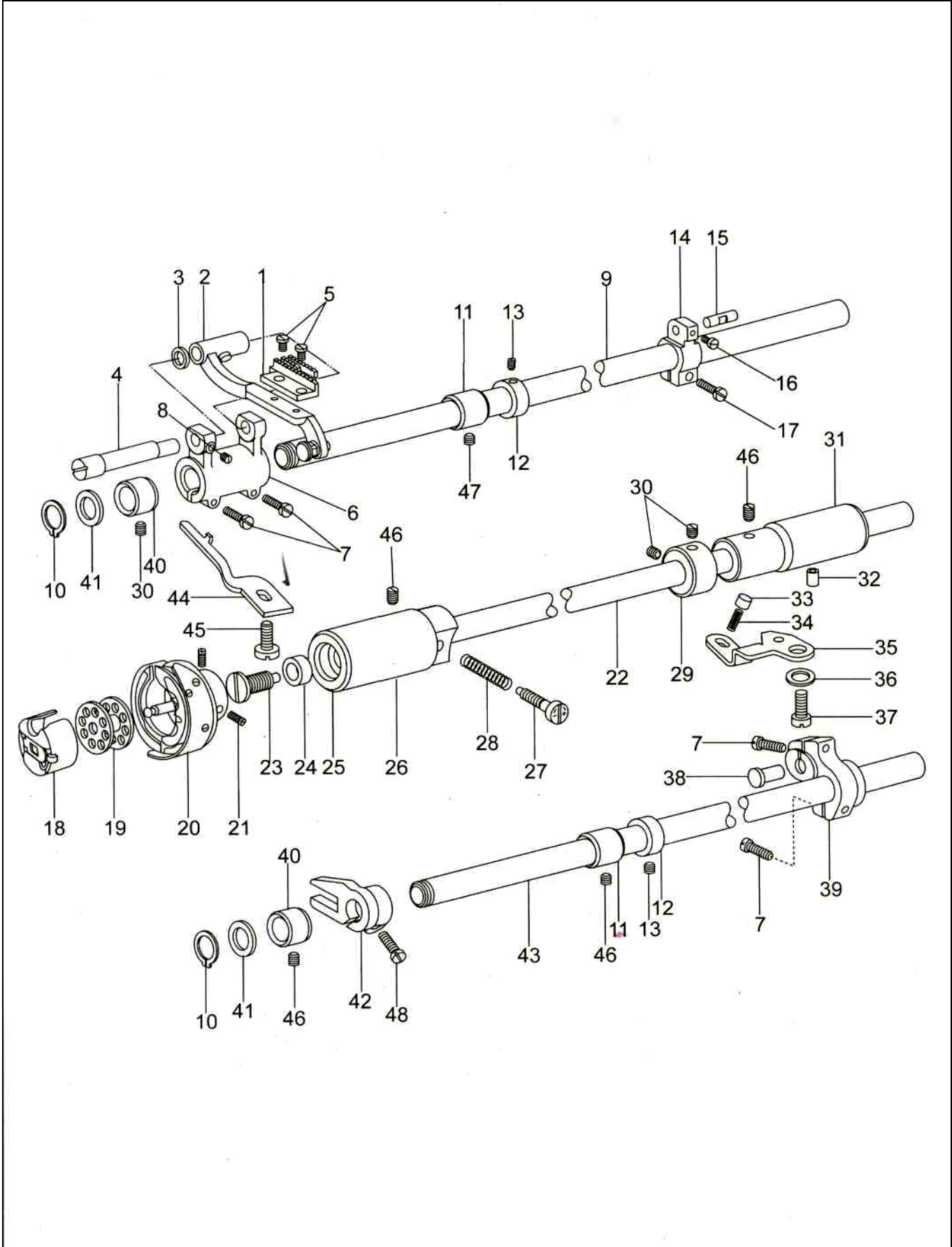

### 3. Feed dog lift and thread looping

No.	Part number	Name	Qt.	Remark
1	22T6-001A3(20T3-007)	Feed dog	1	Part number shown in parentheses is for GC202
2	36T4-001A1 <sub>a</sub>	Feed dog support complete	1	
5	51T5-001A <sub>6</sub>	Washer	1	
4	36T4-001A <sub>2</sub>	Eccentric shaft	1	
5	J0.0.51	Screw	2	
6	4WF2-002	Feed dog support crank	1	
7	J0.0.71	Screw	4	
8	22T2-019	Screw	1	
9	7WF-004	Feed shaft	1	
10		Stop ring	2	Stop ring15 GB894-76
11	7WF2-003	Feed shaft middle bushing	2	
12	22T6-005B <sub>1</sub>	Collar	2	
13	22T3-002B <sub>2</sub>	Screw	4	
14	4WF2-006	Feed shaft crank (left)	1	
15	36T4-004H <sub>01</sub>	Link pin	1	
16	36T5-008E <sub>5</sub>	Screw	1	
17	22T6-008D <sub>3</sub>	Tension screw	1	
18	22T4-016F(33T1-028R)	Bobbin case complete	1	Part number shown in parentheses is for GC202
19	22T4-017(33T1-027)	Bobbin	1	Part number shown in parentheses is for GC202
20	48T4-001A(33T1-018J)	Rotating hook	1	Part number shown in parentheses is for GC202
21	33T1-018J <sub>3</sub>	Screw	3	
22	14WF1-004(36T4-008D <sub>1</sub> )	Rock shaft	1	Part number shown in parentheses is for GC202
23	22T4-001A1 <sub>a1</sub>	Screw	1	
24	22T4-001A1 <sub>a2</sub>	Plug	1	
25	22T4-003	Oil seal	1	
26	4WF1-005	Front bushing for rock shaft	1	
27	22T4-005	Screw	1	
28	22T4-006	Spring	1	
29	22T4-002B <sub>1</sub>	Collar	1	
30	J0.0.35	Screw	3	
31	4WF1-004	Rear bushing for rock shaft	1	
32	22T4-007C <sub>2</sub>	Oil pipe	1	
33	36T4-015	Plunger	1	
34	36T4-016	Spring	1	
35	22T4-010	Stopper	1	
36		Washer	1	Washer 6 GB894-76
37	22T8-009	Screw	1	
38	22T6-007	Hinge pin	1	
39	4WF2-003	Feed dog lift rear crank	1	
40	7WF2-002	Feed shaft front bushing	2	
41	51T5-013	Washer	2	
42	36T4-018H <sub>101</sub>	Feed dog lift fork	1	
43	7WF2-001	Shaft for feed dog lift	1	
44	33T1-029	Hook set bracket	1	
45	22T4-015	Screw	1	
46	J0.0.5	Screw	4	
47	J0.0.40	Screw	1	
48	22T6-008D <sub>3</sub>	Screw	1	

## 4. Feed adjustment mechanism

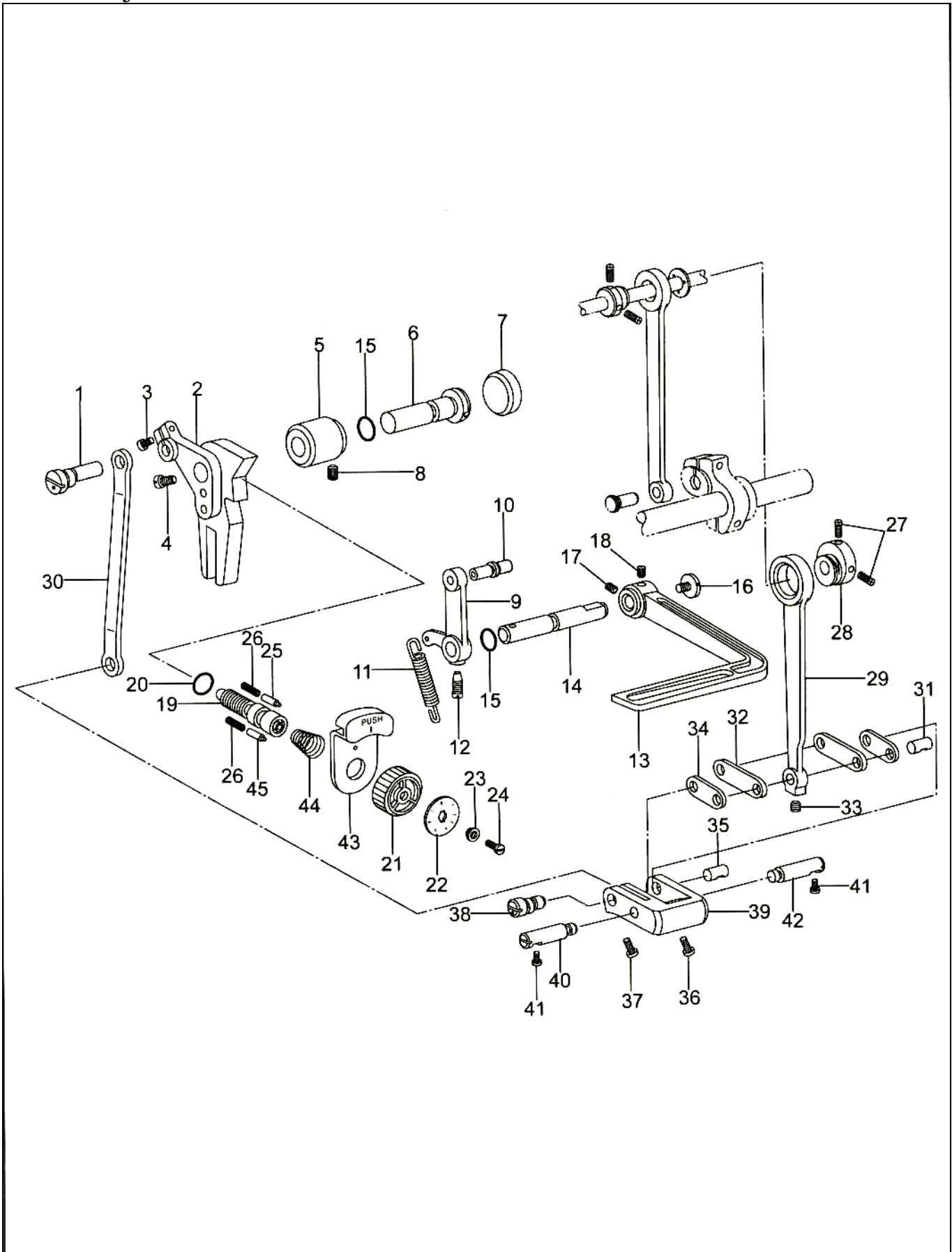

## 4. Feed adjustment mechanism

No.	Part number	Name	Qt.	Remark
1	36T5-001	Link pin	1	
2	4WF5-005	Stitch length bracket	1	
3	22T6-008D <sub>3</sub>	Screw	1	
4	22T5-010D <sub>4</sub>	Screw	1	
5	4WF2-008(5WF1-003)	Bushing	1	Part number shown in parentheses is for GC202
6	22T5-004	Shaft for stitch length bracket	1	
7	36T5-003	Rubber plug	1	
8	J0.0.5	Set screw	1	
9	7WF2-009	Reverse feed lever crank	1	
10	7WF2-008A	Shaft for block	1	
11	22T5-012E <sub>2</sub>	Spring	1	
12	22T5-013	Screw	1	
13	7WF2-007A	Reverse feed lever	1	
14	22T5-001D <sub>2a</sub>	Pin shaft	1	
15		O-type ring	2	"O" type 8X1.9 GB1235
16	22T5-010D <sub>3</sub>	Tension screw	1	
17	17T5-016	Screw	1	
18	17T5-017	Set screw	1	
19	36T5-007D <sub>1</sub>	Screw bolt for stitch length	1	
20		O-type rubber ring	1	"O" type 14X2.4GB1235
21	36T5-007D <sub>2</sub>	Dial cup	1	
22	4WF2-004A	Dial face	1	
23	36T5-007D <sub>4</sub>	Screw bushing	1	
24	36T5-007D <sub>5</sub>	Screw	1	
25	36T5-012	Stop pin	1	
26	22T5-009	SD spring	1	
27	36T3-003D <sub>2</sub>	Screw	j	
28	36T5-008E <sub>1</sub>	Feed cam	1	
29	4WF2-009A	Feed link	1	
30	4WF2-009B	Stitch length adjusting link	1	
31	82T2-003C <sub>1a10-1</sub>	Pin	1	
32	36T5-008E <sub>4H02</sub>	Link	2	
33	36T5-008E <sub>5</sub>	Screw	1	
34	36T5-008E <sub>4H01</sub>	Link	2	
35	82T2-003C <sub>1a10-2</sub>	Pin for link	1	
36	36T5-008E <sub>7</sub>	Screw	1	
37	36T5-008E <sub>8</sub>	Screw	1	
38	36T5-008E <sub>9</sub>	Link eccentric shaft	1	
39	36T5-008E <sub>10</sub>	Stitch length adjusting crank	1	
40	4WF2-010(5WF1-002)	Set pin (left)	1	Part number shown in parentheses is for GC202
41	22T6-008D <sub>3</sub>	Set screw	2	
42	36T5-009H01(5WF1-001)	Set pin (right)	1	Part number shown in parentheses is for GC202
43	7WF2-005	Push lever	1	
44	36T5-010	Spring	1	
45	7WF2-006	Stop pin	1	



## 5. Presser bar

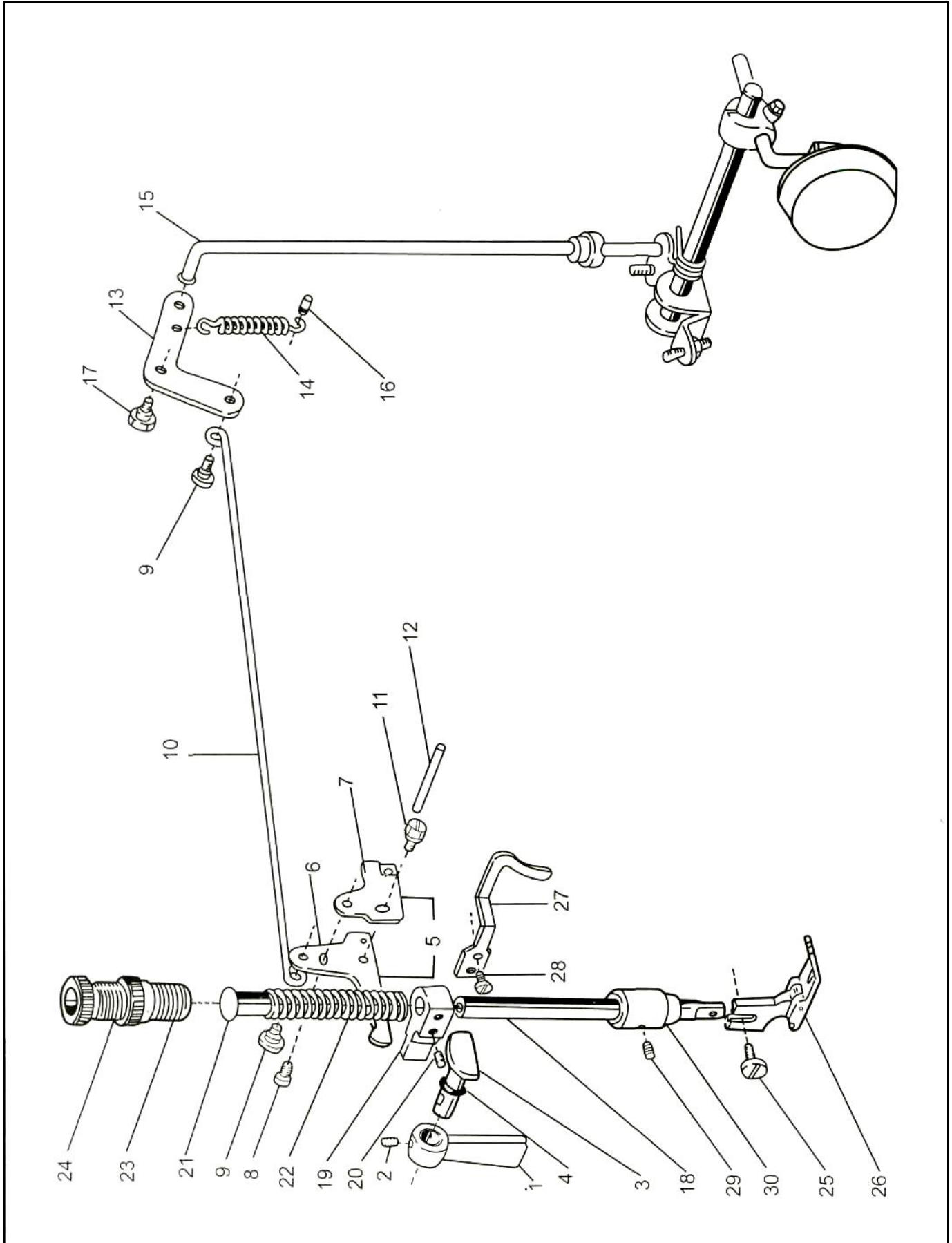

## 5. Presser bar

No.	Part number	Name	Qt.	Remark
1	34T3-304	Presser foot lift bar	1	
2	22T7-001A <sub>2</sub>	Screw for presser foot lift bar	1	
3	1KT4-005	Presser bar lift cam	1	
4		O-type ring	1	O-tpye8X1.9GB1235
5	22T7-004B <sub>1</sub>	Knee lifter lever complete	1	
6	22T7-004B <sub>1a</sub>	Knee lifter lever (left)	1	
7	22T7-004B <sub>1b</sub>	Thread releasing cam	1	
8	22T7-004B <sub>1c</sub>	Screw (left)	1	
9	22T7-004B <sub>2</sub>	Knee lifter link hinge screw	2	
10	22T7-004B <sub>3</sub>	Knee lifter drawing bar	1	
11	22T7-005A	Screw	1	
12	22T7-006	Thread releasing lever	1	
13	22T7-007C <sub>1</sub>	Knee lifter lever (right)	1	
14	22T7-007C <sub>2</sub>	Spring	1	
15	4WF3-001(1KT4-004)	Knee lifter connecting rod	1	Part number shown in parentheses is for GC202
16	22T7-008	Pin	1	
17	22T7-005B	Screw	1	
18	22T7-010	Presser bar	1	
19	22T7-011D1	Guide for presser bar	1	
20	6I-04-01/B308	Screw	1	
21	22T7-012	Screw bolt for presser bar spring	1	
22	33T3-002	Spring	1	
23	14WF3-001(15WF3-001)	Pressure adjusting screw	1	Part number shown in parentheses is for GC202
24	1KT4-002	Lock nut	1	
25	7WF5-007	Screw for presser foot	1	
26	48T7-003(22T7-017F)	Presser foot complete	1	Part number shown in parentheses is for GC202
27	22T2-016	Thread guide	1	
28	33T3-006	Screw for thread guide	3	
29	22T2-013	Screw	1	
30	33T3-005(34T3-305)	Bushing for presser bar	1	Part number shown in parentheses is for GC202

## 6. GC201 Oil pump

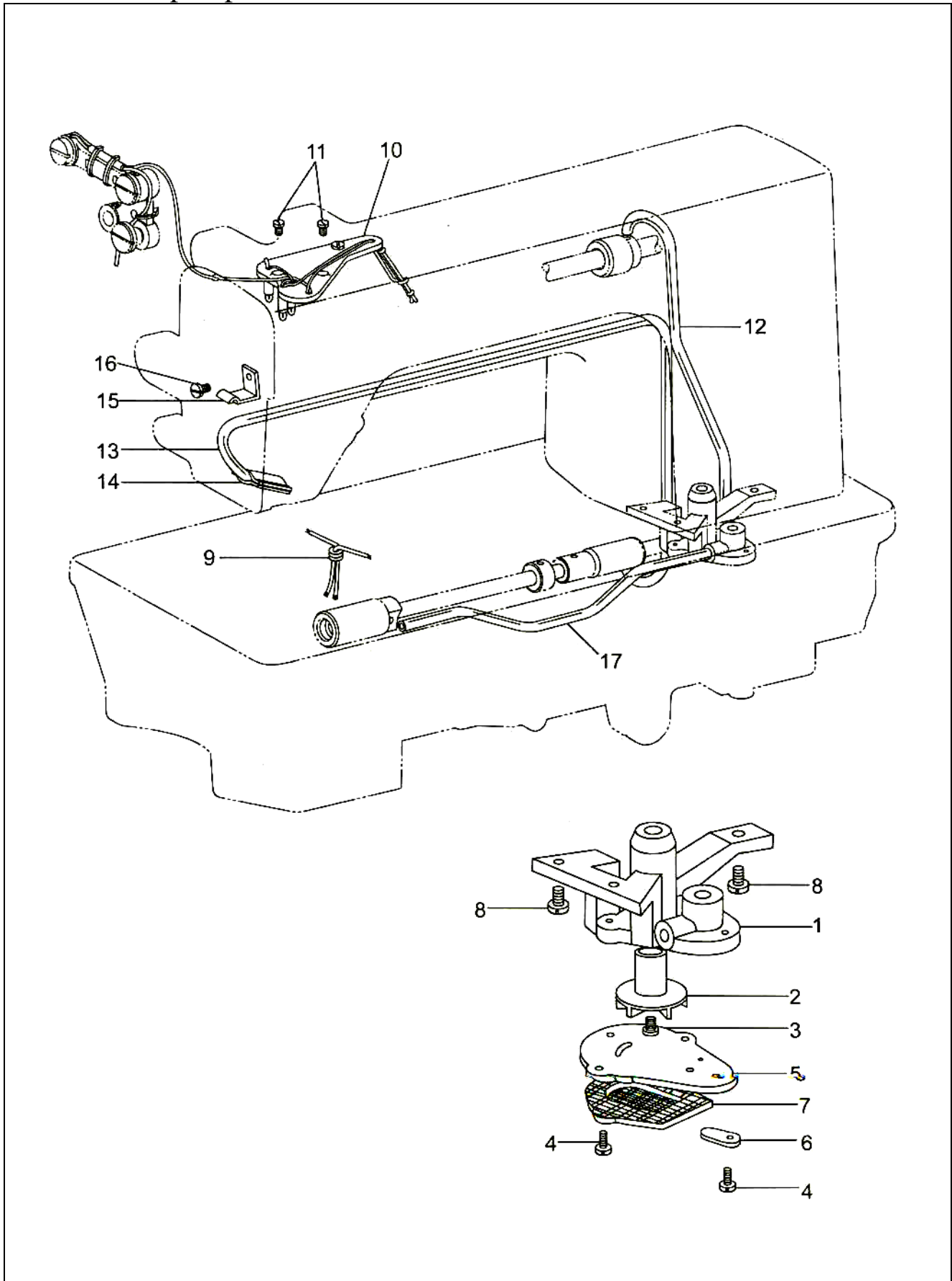

## 6. GC201 Oil pump

No.	Part number	Name	Qt.	Remark
1	22T8-001	Oil pump	1	
2	22T8-002	Big gear for oil pump	1	
3	22T8-003	Screw	1	
4	22T8-004	Screw	3	
5	22T8-006	Cover for oil pump	1	
6	22T8-007	Adjusting plate for oil pump	1	
7	22T8-008A	Filter complete	1	
8	22T8-009	Screw for oil pump	3	
9		Oil box	2	
10	22T8-011C	Oil wick set plate complete	1	
11	22T8-012	Screw	2	
12	22T8-013D	Oil pipe complete for upper shaft	1	
13	22T8-014	Oil return pipe	1	
14	22T8-015	Oil felt	1	
15	22T8-016	Oil return pipe clamp	1	
16	20T4-006	Screw	1	
17	17WF4-009	Oil pipe complete for lower shaft	1	

## 7. GC202 Oil pump

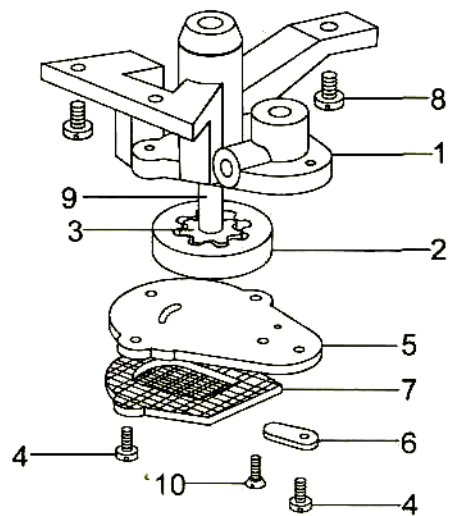
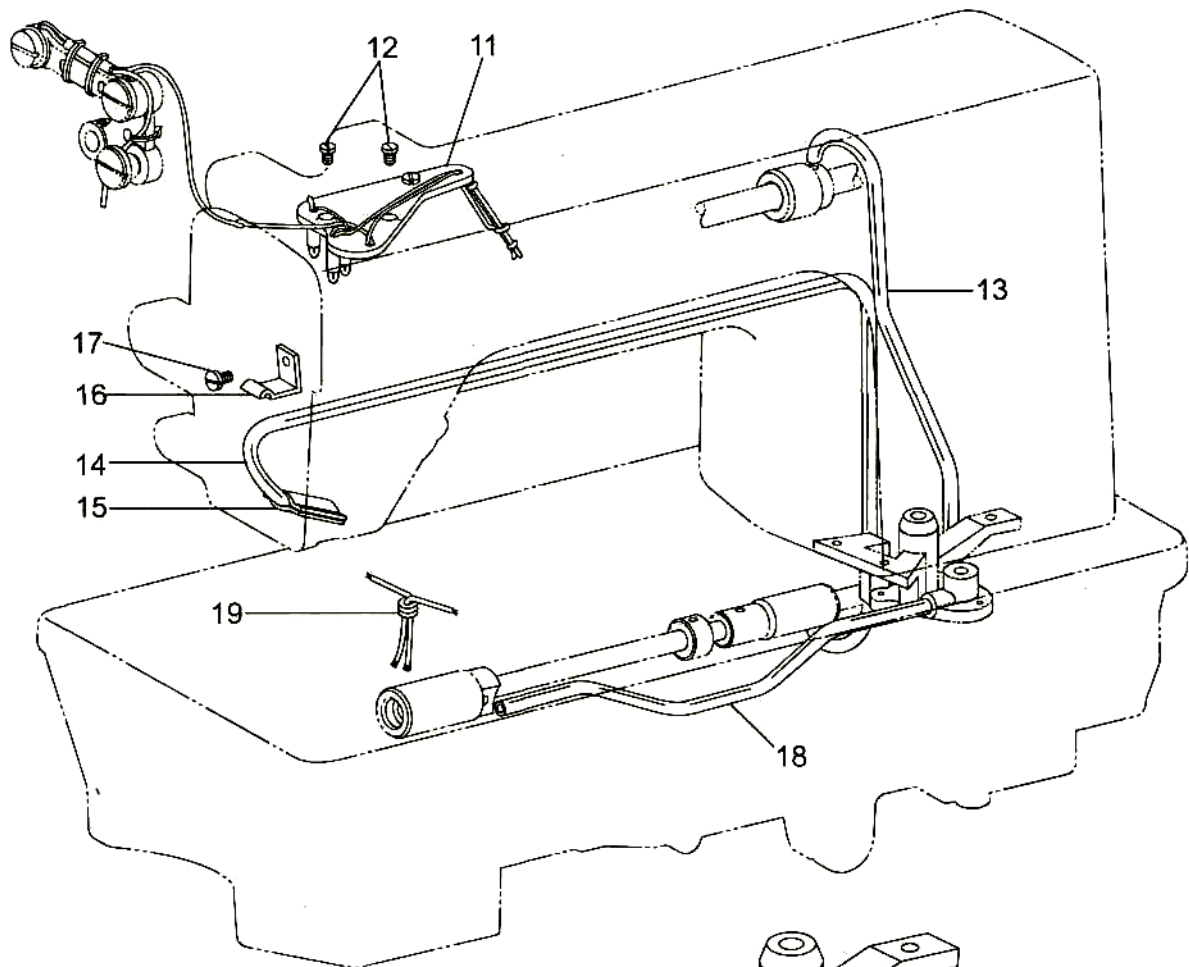

## 7. GC202 Oil pump

No.	Part number	Name	Qt.	Remark
1	15WF4-003	Oil pump	1	
2	15WF4-006	Big gear for oil pump	1	
3	15WF4-007	Small gear for oil pump	1	
4		Screw	3	M3X10 GB67-85
5	15WF4-004	Cover for oil pump	1	
6	22T8-007	Adjusting plate for oil pump	1	
7	22T8-008A	Filter complete	1	
8	22T8-009	Screw for oil pump	3	
9	15WF4-005	Shaft for oil pump	1	
10		Screw	2	M3X6 GB68-85
11	22T8-001	Oil wick set plate complete	1	
12	22T8-012	Screw	2	
13	22T8-013	Oil pipe complete for upper shaft	1	
14	22T8-014	Oil return pipe	1	
15	22T8-015	Oil felt	1	
16	22T8-016	Oil return pipe clamp	1	
17	22T4-006	Screw	1	
18	22T8-011B	Oil pipe complete for lower shaft	1	
19		Oil box	2	

## 8. Accessories

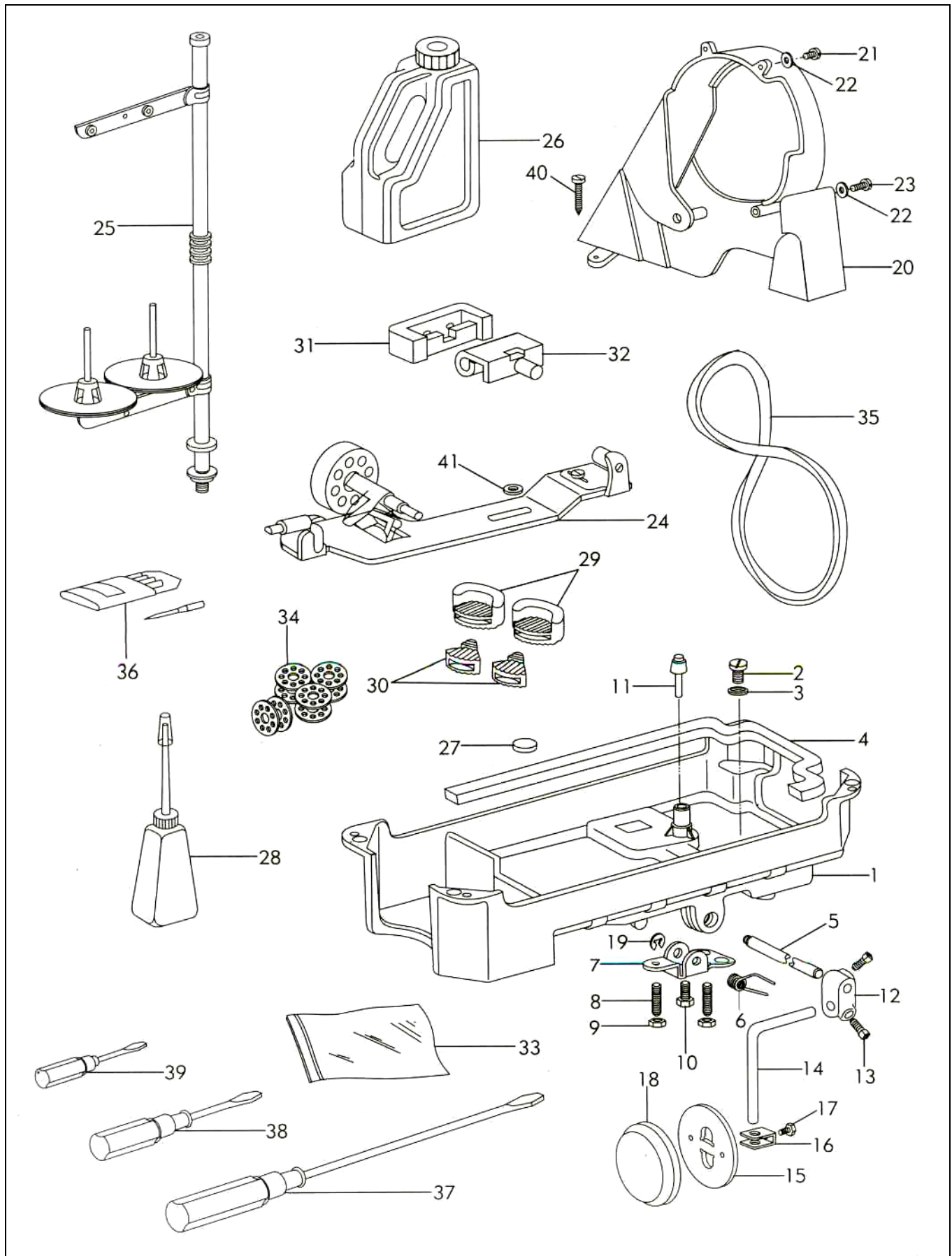

## Accessories

No.	Part number	Name	Qt.	Remark
1	4WF5-001	Oil reservoir	1	
2	22T9-001A <sub>2</sub>	Screw	1	
3	22T9-001A <sub>3</sub>	Washer	1	
4	2KT9-008	Gasket	1	
5	22T9-001A <sub>6</sub>	Hinge pin	1	
6	22T9-001A <sub>7</sub>	Spring	1	
7	22T9-001A <sub>8</sub>	Knee lifter stop bracket	1	
8	22T9-001A <sub>9</sub>	Screw	2	
9	22T9-001A <sub>10</sub>	Nut	7	
10	2KT9-005	Screw	1	
11	22T9-003B <sub>1</sub>	Knee lifter prop bar	1	
12	22T9-003B <sub>3</sub>	Connector	1	
13	22T9-003B <sub>4</sub>	Screw	2	
14	22T9-003B <sub>2</sub>	Bent rod	1	
15	22T9-003B <sub>5</sub>	Bell	1	
16	22T9-003B <sub>6</sub>	Bell bracket	1	
17	22T9-003B <sub>7</sub>	Screw	1	
18	22T9-003B <sub>8</sub>	Pat	1	
19		Split stop ring	1	Stop ring 9 GB896-76
20	1KT6-001	Belt guard complete	1	
21	4F-004	Screw(small)	2	M4X8 GB67-85
22		Washer	2	GB848-85-4
23	4F-005	Screw(big)	2	M5X12GB67-85
24	S14420020	Thread winder complete	1	
25	GJX-2	Spool stand complete	1	
26	22T9-017	Oil tank	1	
27	22T9-013	Magnet	1	
28	33TF-011	Oil pot	1	
29	22T9-009	Cushion(big)	2	
30	22T9-010	Cushion(small)	2	
31	33T1-004	Rubber coat	2	
32	22T9-007F <sub>2</sub>	Hinge	2	
33	33TF-010	Parts bag	1	
34	14WF1-003(33T1-027)	Bobbin	5	Part number shown in parentheses is for GC202
35		V-type belt	1	O-type 1041
36	33TF-015	Needle	1big	DpX5 23 <sup>#</sup> (GC202 21 <sup>#</sup> )
37	33TF-012	Screwdriver(big)	1	
38	33TF-013	Screwdriver(middle)	1	
39	33TF-014	Screwdriver(small)	1	
40		Wood screw	4	GB5282-85 ST4.8X 19
41		Washer	2	GB848-85-6